

S5001

2014-UP CHEV/GMC
SILVERADO/SIERRA 1500,
4.3L V6, 5.3L V8, MUFFLER BYPASS, 3.0"

MBRP®

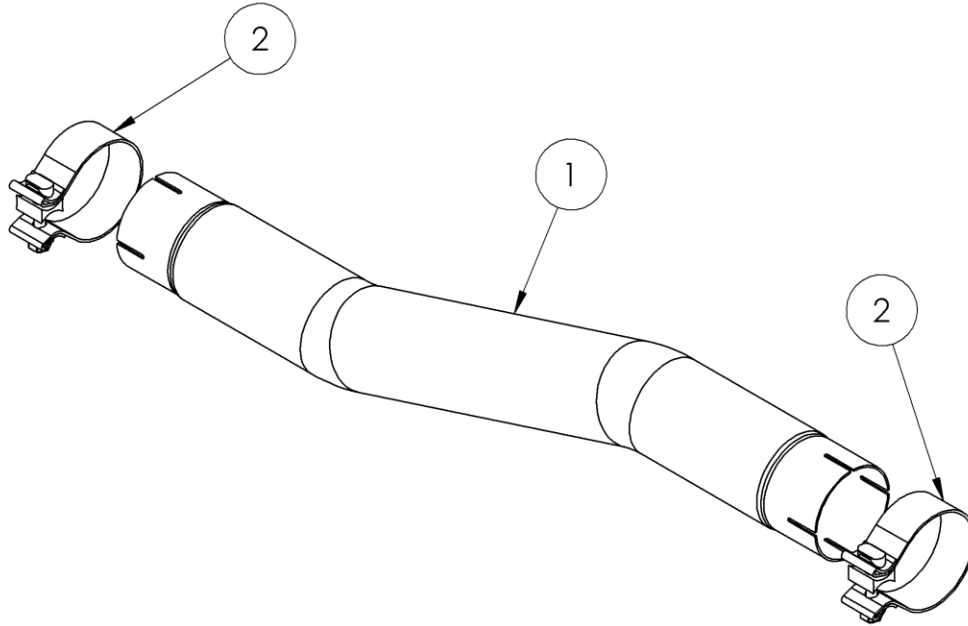

ITEM	DESCRIPTION	QTY.
1	MUFFLER BYPASS PIPE	1
2	2.75"CLAMP	2

PLEASE READ BEFORE STARTING INSTALLATION

While MBRP has made every effort to ensure that all components of this system are of superior quality and properly packaged, it is the installer's responsibility to ensure the following before removal of the factory exhaust:

- that ALL components shown above are present.
- that ALL mating components fit together.
- that there are no damaged components.
- that the system you have purchased is appropriate for your vehicle year, model and configuration.
- that the system will not interfere with any modifications previously installed or planned.
- that you have read and understand these instructions.

If you have any questions or are uncertain about any aspect of the installation of this system to your vehicle please contact your dealer before commencing installation.

MBRP

Removal of Stock System



Figure 1

1. Mark cut lines on the OEM exhaust as close to the weld seam as possible on the valve side, and approximately 2.5" from the weld seam on the opposite side.

Refer to figures 1 and 2

2. Support the Muffler and cut on previously marked lines to remove the muffler from the vehicle.

Refer to Figure 3

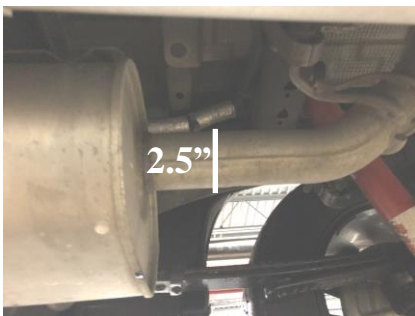

Figure 2

Installation of MBRP Performance Exhaust

1. Install the 2.75" Band Clamps onto both ends of the Muffler Bypass Pipe.

2. Install the Muffler Bypass Pipe over the rear section of the OEM exhaust first. Slide it on far enough so that the other side of the Muffler Bypass Pipe can be aligned with the front half of the OEM Exhaust.



Figure 3

3. Slide the Muffler Bypass Pipe forward and over the front half of the OEM Exhaust. Adjust the rotation of the pipe so that the outlet sits slightly higher than the inlet side. Reference the OEM Muffler for alignment.

Refer to Figure 4.



Figure 4

4. Carefully align the system. Align the edge of each band clamp with the edge of the joint it is connecting. Tighten all hardware and clamps, starting at the front and working rearward to secure the system. Check along the full length of the exhaust system to ensure there is adequate clearance for fuel lines, vent lines, brake lines, frame, bodywork, suspension and any wiring, etc. If there is any interference detected, relocate or adjust to provide adequate clearance. Ensure all clamp connections are secure and components are unable to rotate or slide. Band clamps require approximately 45 lb-ft (60 N-m) of torque. Verify clearances, system security and band clamp torque after 30-60 miles (50-100 km) of driving.

Congratulations! You are ready to begin experiencing the improved power, sound and driving excitement of your **MBRP** Performance Exhaust system. We know you will enjoy your purchase.